

General Description

Many controller-, data acquisition- and user information-applications require sensing environmental temperatures with IC-external sensors. The IP cell generates the required temperature independent reference current and voltage to set up a defined operating point of the sensor. Analogue-to-digital conversion is performed after analogue pre-processing by the Instrumentation Amplifier. The temperature depended sensor voltage is between 80mV and 140mV with a current of 100µA. This current is driven into the sensor for a short measurement period, in which the sensor voltage is amplified and sampled by a sample and hold block. This block holds the voltage during analogue-to-digital conversion process. A counting analogue-to-digital converter is implemented for conversion. The architecture needs 2^N clock cycles, where N is the number of output bits. The chosen converter type combines very low supply current with inherent monotony. A resolution of 13Bit is achieved without excessive trimming.

Ratings, Parameters and Conditions

Parameter / Condition	Symbol	Min	Typ.	Max	Unit	Comment
Electrical Parameters:						
Supply voltage	V_{dda}	2.7	3	3.3	V	
Supply current	$I_{dd} + I_{dda}$		800		µA	during measurement period
Supply current	$I_{dd} + I_{dda}$		50		µA	average
Input voltage high	V_h	$0.8 \cdot V_{dd}$			V	
Input voltage low	V_l			$0.2 \cdot V_{dd}$	V	
Effective resolution	N_{eff}		12		Bit	in sensor typical operating range
Repeatability	DT_{repeat}			0.1	K	
Accuracy uncertainty	DT_{abs}			0.4	K	
Power up time	$T_{startup}$			5	ms	
Response time	T_{res}			5	s	
Conversion time	T_{conv}		250	250	ms	
Input clock frequency	F_{clk}		32.768		kHz	
Absolute Maximum Ratings:						
Operating Temperature	T_{range}	-40	27	125	°C	
Supply Voltage	V_{dd}	-0.3		7	V	
Input Voltage	V_{in}	-0.3		$V_{dd}+0.7$		
Output Voltage	V_{out}	-0.3		$V_{dd}+0.7$		

Block Schematic:

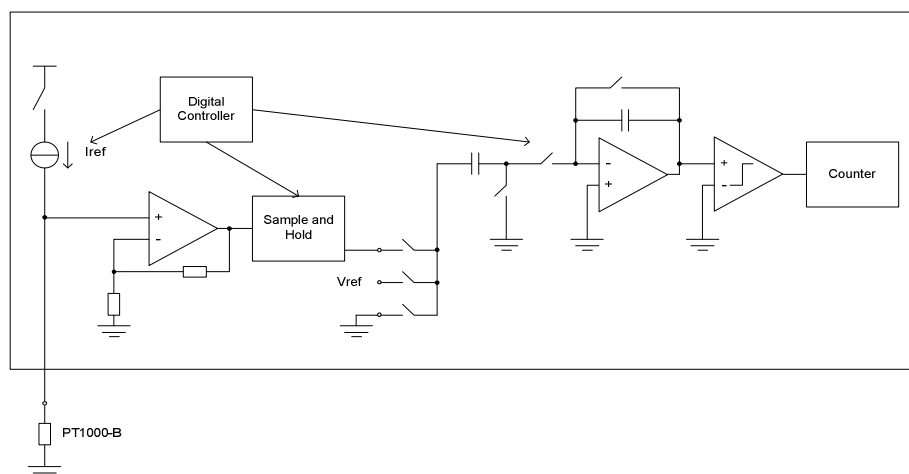

Dieses Projekt wird im Rahmen der Technologieförderung mit Mitteln des Europäischen Fonds für regionale Entwicklung (EFRE) und mit Mitteln des Freistaates Sachsen gefördert.