

### PE4301 Power Factor Correction IC

The PE4301 represents a new dimension of integrated circuits providing power factor correction. Through its implemented safety features, it increases the reliability of operation. Additionally, by saving power, the PE4301 reduces system cost.

#### Description

The PE4301 is an 8 pin control IC for power factor correction converters. It is suitable for a wide range of line input applications from 85 to 265 VAC. The IC supports converters in boost topology and operates in continuous conduction mode (CCM) with peak current control.

A new regulation principle modulates the pulse width and the switching frequency, raising the adjustment range considerably. This enables power supplies from 70W up to 280W with excellent power factor. On top, there is no need to change the external circuitry. Even more, this power range can be widened, depending on the input voltage (see figure 2).

Two loops are combined to control the amplitude, phase and shape of the input current, with respect to the input voltage, giving near-unity power factor. The IC is equipped with various protection features to ensure safe operating condition for the system and for the device.

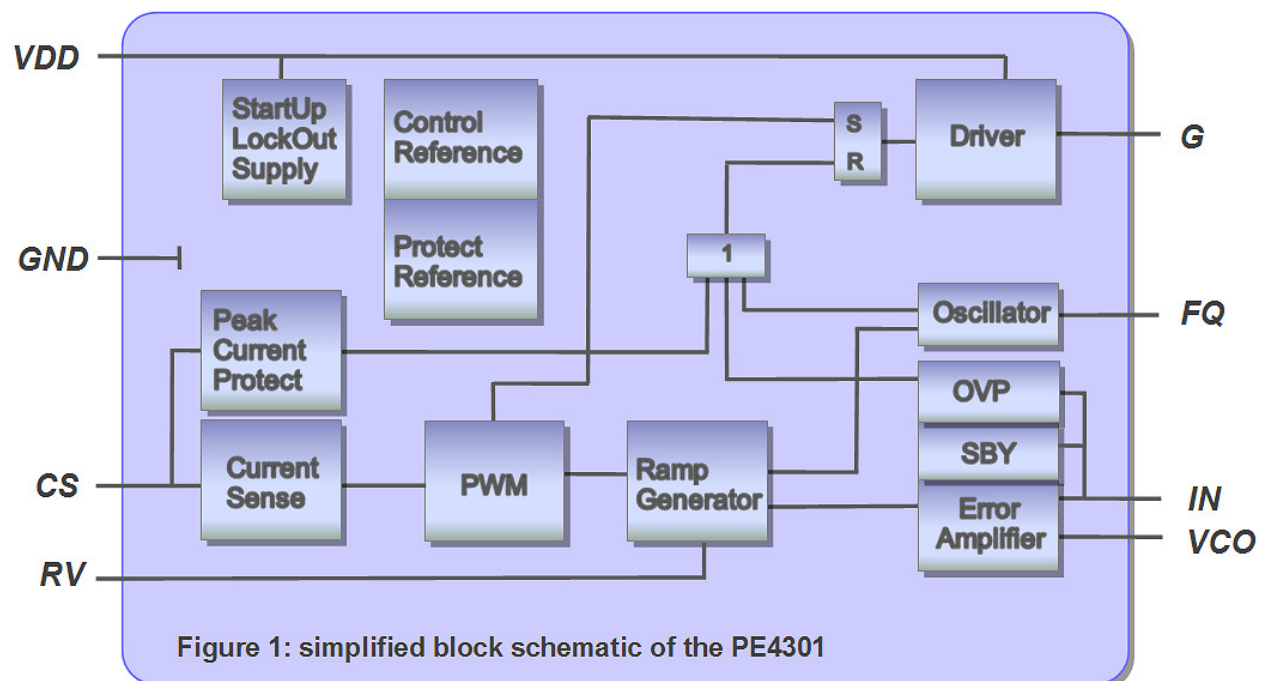

### Features

- low total harmonic distortion (THD)
- under voltage lockout with > 8V hysteresis
- over voltage and peak current protection with independent reference
- excellent power factor at high and low output power with new regulation principle
- good power factor at zero crossing input voltage
- internal clamping resistor at driver output
- low operating current (< 500 $\mu$ A)
- low start-up current (< 5 $\mu$ A)
- disable function (< 200 $\mu$ A)
- fast driver switch off speed

### Applications

- AC/DC converter
- Electric Light Ballast
- PC & TV & Monitor SMPS
- Low- & Mid-Power Applications

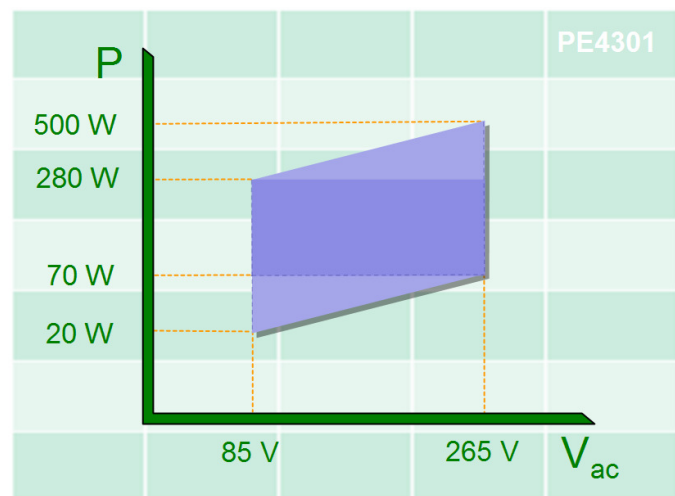

### Parameters

input voltage range	85 to 265 VAC
operating current (without driver load)	<500 $\mu$ A
start-up current	<5 $\mu$ A
start-up/lock-out hysteresis	>8 V
driver load	5nF
switching frequency	40..300 kHz
operating temperature	-40..125 $^{\circ}$ C
supply voltage	8..30 V
output voltage regulation	$\pm$ 1%

Important Notice: Productivity Engineering GmbH (PE) reserves the right to make corrections, modifications, enhancements, improvements, and other changes to its products and services at any time and to discontinue any product or service without notice. Customers should obtain the latest relevant information before placing orders and should verify that such information is current and complete.

© 2016 PE GmbH. All rights reserved.