

PE3011 HF-RFID Sensor Data Monitoring IC

The PE3011 widens the potential of RFID and enables new applications with cost and performance optimized products. Using this IC, data monitoring systems fit on a smart label and replaces classic complex, multi-component solutions. With its integrated temperature sensor, capacitive interface and the standard interface, the PE3011 represents a sensor data monitoring system-on-chip.

Description

The PE3011 is an ISO15693 compliant RFID transponder chip, with extended functionality to measure and monitor timing or event driven data. The IC measures time coded data from sensors (internal temperature, external capacitive sensors) and stores these data in an integrated EEPROM. These data have user defined formats (temperature, pressure, shock, humidity, passing control data, etc.). The IC can be used for logistic purposes to check various sensor functions in a defined timeframe. In data monitoring operation (without RF field) the IC is supplied with a battery. All external data can be stored via serial interface (SPI). An external microcontroller can also access stored data and transfer these data to or from other components.

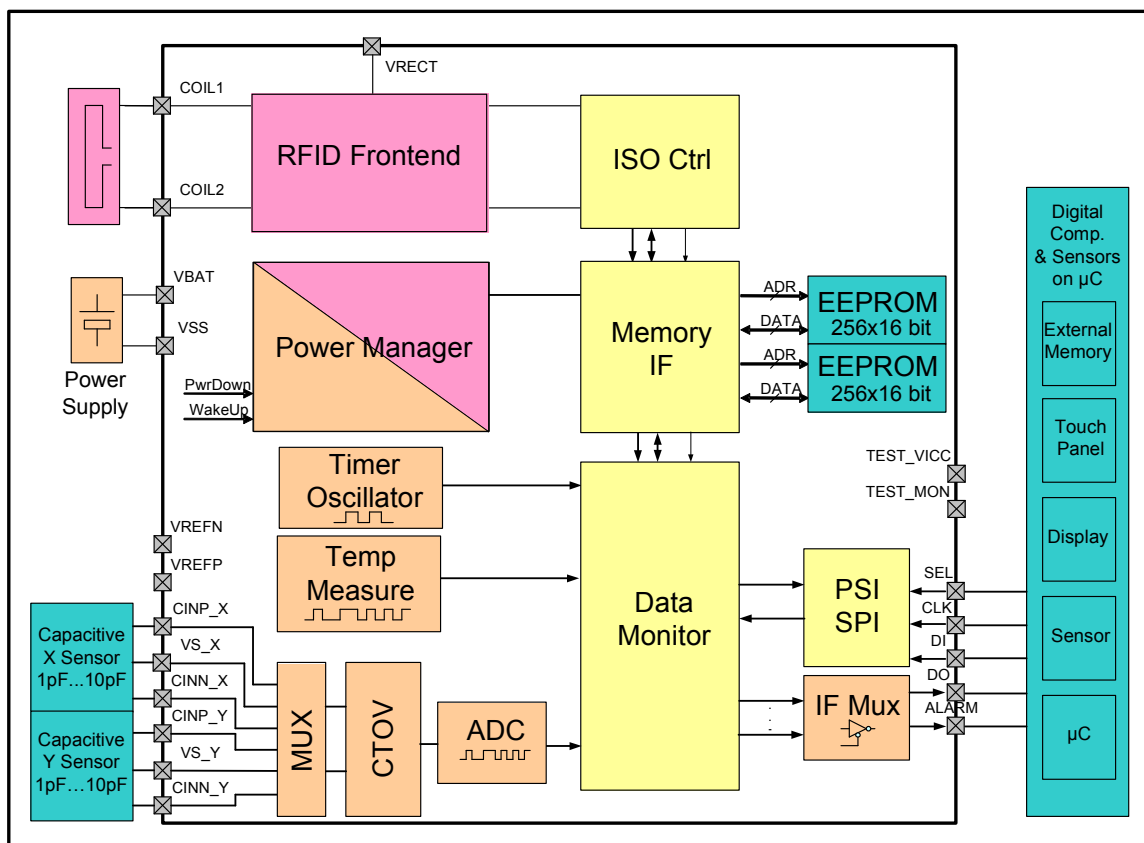

PE3011 block diagram with external application circuits

Features

- Passive transponder chip featuring ISO15693 protocol
- Monitoring of time, (chip) temperature and external capacitive sensor value over a defined interval
- Storing measured data in EEPROM with user defined parameters (event and timing controlled)
- Alarm port for immediate information about threshold exceeding sensor data
- Energy supply of IC over RFID field and/or connected battery; read and write of EEPROM without battery possible
- 8kBit password protected EEPROM read- and writeable over RF field and data monitor
- ADC with two analog sensor ports for external differential/single-ended capacitive sensors (programmable)
- Connection of external functions over SPI interface (μ C, display and/or sensors)
- Minimal power consumption (Power Manager)

Applications

- Temperature curve tracing for sensitive grocery products and pharmaceutical product logistic (blood and plasma preservation)
- Direct external capacitive sensor curve tracing for logistic (humidity, pressure) of sensitive appliance (i.e. paper industry, chemicals)
- Direct external capacitive sensor interrupt for sensitive equipment (shock, tilt) as out-of-limits application
- Wide range biunique item identification
- Observation of hazardous materials
- with optional external digital sensors and μ C: data tracking for production system (i.e. machinery production), display monitor for wireless data (contactless data display)

Parameters

- operating frequency 13.56 MHz
- standard conformity ISO15693
- battery supply voltage 2.4 – 3.6 V
- power consumption (max) 5 μ W (1mW interrupt mode)
- internal EEPROM size 8 kbit
- operating temperature -40 .. 85°C
- internal sensor precision up to \pm 0.5 K
- external capacitiv sensor range 1 to 10 pF \pm 2.0 pF
- external capacitive sensor precision 1fF differential;
2fF single ended
- timer accuracy \pm 3 %
- read sensitivity (typ) -6 dB
- write sensitivity (typ) -4 dB

Functional Block Description

Analog RFID Frontend and ISO15693 Protocol Controller

The RFID Front end is used for communication with standard readers and to extract supply power from the RF field. Main blocks are:

- Rectifier, input voltage multiplier and Voltage limiter
- Receiver unit composed of envelope detector, demodulator and decoder
- Transceiver unit composed of modulator
- Command decoder (Command Control Engine) ISO15693 conform

Power Manager

The Power Manager is used to control several power domains and restrictions to achieve minimal power consumption. Main blocks are:

- Control RF power supply, Control battery charge
- Control data monitor supply, Control power supply to EEPROM
- Wakeup, sleep and power down controlling

Data Monitoring and Sensor Measurement System

The internal block for data monitoring is used to control a user defined data capturing with timing information. No external components are necessary for temperature measurement with user defined temperature processing. In a defined non volatile memory (EEPROM) area it is also possible to capture data from capacitive external sensors.

Main blocks are:

- Calibrated RCoscillator for a nominal frequency: time base for timing information and measuring the sensor data. This oscillator is supplied by the battery.
- Two point calibrated temperature sensor: integrated sensor to measure the chip temperature.
- Power down mode in general stop mode and sleep mode during measurement intervals. Wake up during measurement and data storage in memory.
- Control structure for two external capacitive sensors.

Memory Controller and EEPROM

The integrated EEPROM is a non volatile read/write memory. In accordance to ISO15693 specification the memory is divided into UID, MONREG, MONDAT and USER bank. User data will be stored in USER Bank and monitoring data will be stored in MONDAT bank. The MONREG block is defined for trimming and calibration data. Main blocks are:

- Charge pump: to write and erase the EEPROM
- Internal access control: to control timing, data monitoring, data processing, memory read and write operation
- External access control: to select functions for internal and/or external data transfer

Communication Controller (SPI)

For a direct communication with external components a serial standard interface which is programmable for several applications (μ C conform) is implemented. The serial interface enables a direct data transfer to the internal memory.

Differential Analog Sensor Interface

For external capacitive sensor signals a bridge amplifier and a 12bit analog to digital converter is implemented. These components are fully parameterizable for :

- assembly levels, speed, accuracy, normalisation, interrupt levels

via registers and EEPROM addresses.

A differential or single ended capacitive variation is defined from 1pF to 10pF.

Contact Addresses

Germany

Stuttgart

Productivity Engineering
Process Integration GmbH
Behringstrasse 7
D-71083 Herrenberg
Germany
Phone.: +49 (0) 70322798 0
Fax: +49 (0) 70322798 29
Email: info@pe-gmbh.com
Web: www.pe-gmbh.com

Dresden

Productivity Engineering GmbH
Branch
Sachsenallee 9
D-01723 Kesselsdorf
Germany
Phone.: +49 (0) 35204777 00
Fax: +49 (0) 35204777 000
Email: info@pe-gmbh.com

Important Notice

Productivity Engineering GmbH (PE) reserves the right to make corrections, modifications, enhancements, improvements, and other changes to its products and services at any time and to discontinue any product or service without notice. Customers should obtain the latest relevant information before placing orders and should verify that such information is current and complete. All products are sold subject to PE's terms and conditions of sale supplied at the time of order acknowledgment. PE warrants performance of its hardware products to the specifications applicable at the time of sale in accordance with PE's standard warranty. Testing and other quality control techniques are used to the extent PE deems necessary to support this warranty. Except where mandated by government requirements, testing of all parameters of each product is not necessarily performed. PE assumes no liability for applications assistance or customer product design. Customers are responsible for their products and applications using PE components. To minimize the risks associated with customer products and applications, customers should provide adequate design and operating safeguards. PE does not warrant or represent that any license, either express or implied, is granted under any PE patent right, copyright, mask work right, or other PE intellectual property right relating to any combination, machine, or process in which PE products or services are used. Information published by PE regarding third-party products or services does not constitute a license from PE to use such products or services or a warranty or endorsement thereof. Use of such information may require a license from a third party under the patents or other intellectual property of the third party, or a license from PE under the patents or other intellectual property of PE. Resale of PE products or services with statements different from or beyond the parameters stated by PE for that product or service voids all express and any implied warranties for the associated PE product or service and is an unfair and deceptive business practice. PE is not responsible or liable for any such statements.

© 2016 PE GmbH. All rights reserved.